

BNC F/F Adaptor bulkhead	REF : 60145	A
-------------------------------------	--------------------	----------

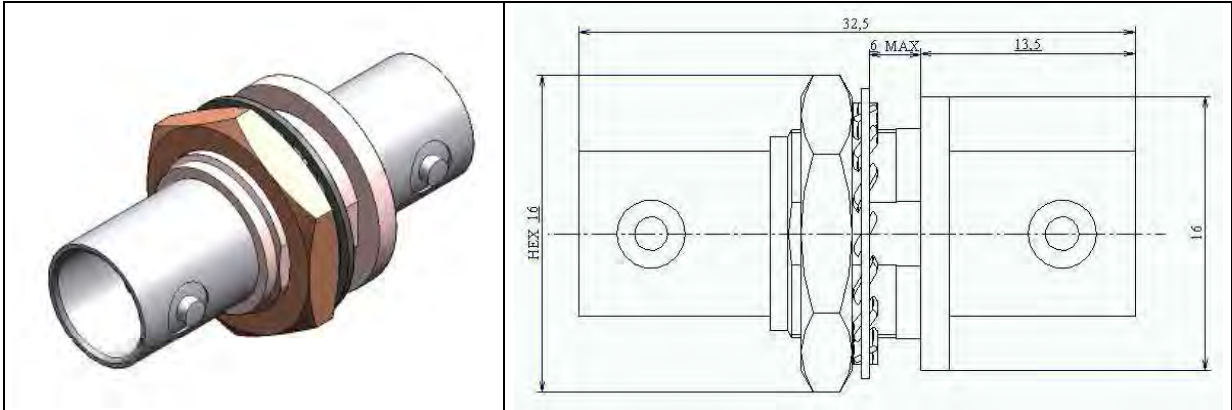

Impedance	75 ohms
Proof Voltage	1500 Volts mini
Insulation resistance	> 5000 Mohms
Shield effectiveness	< -90 dB
Materials	
- Body, Nut, Ferrule	Brass
- Insulator	PTFE
- Overmolding	PA
Protection	
- Body, Nut, Ferrule	Nickel
- Center Contact	Gold
Climatic Category	-40°C / +80°C

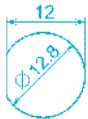

Panel cut out

	Date : 20/06/07	Edition A
	Creation: BDa	Validation: BG